

ULTRALITE 290FD

SPECIFICATIONS

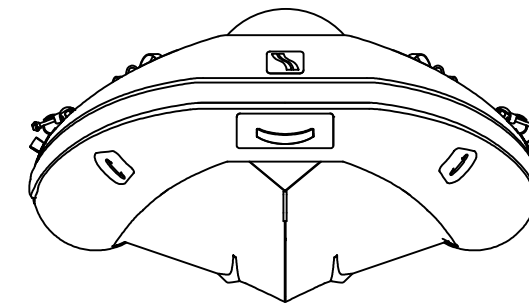
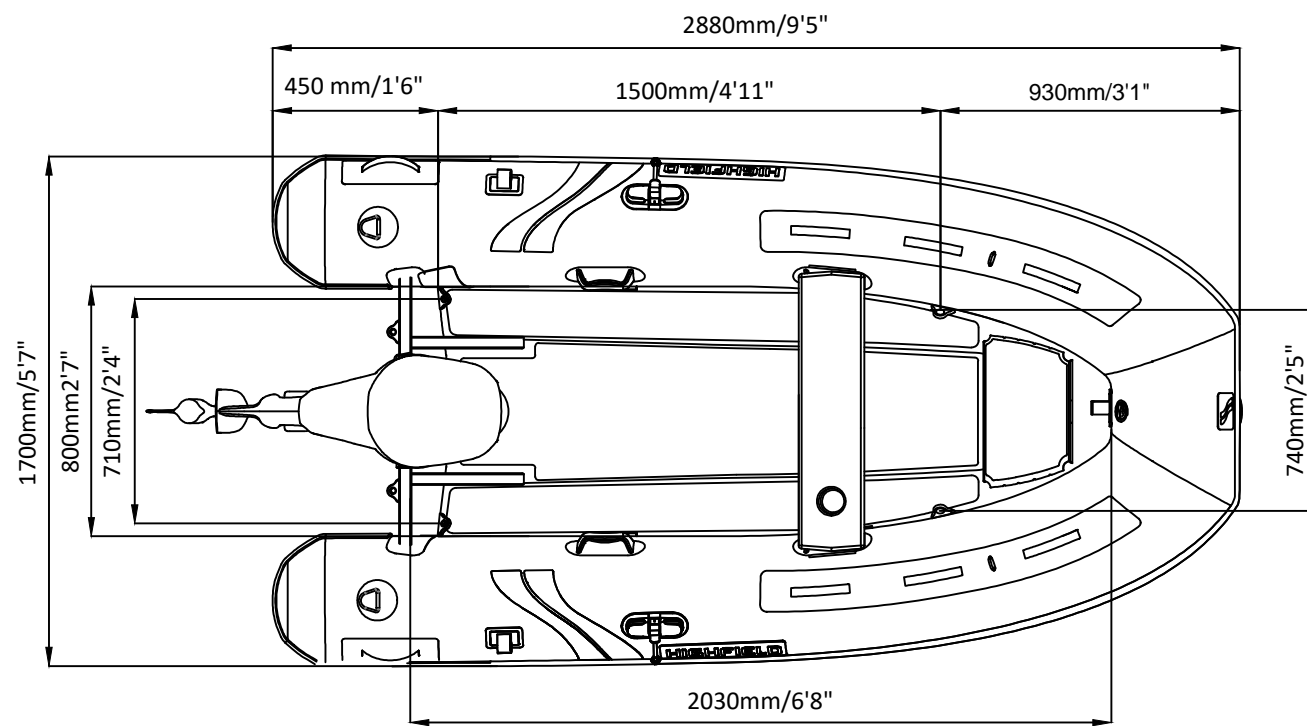
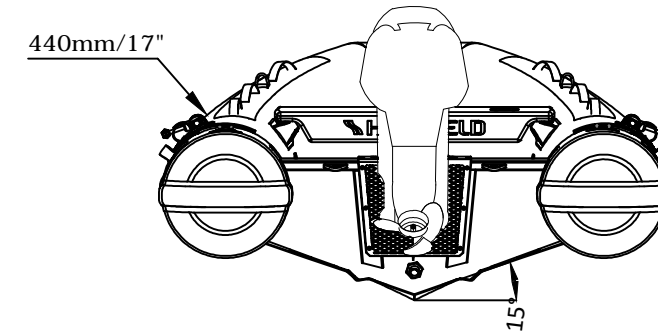
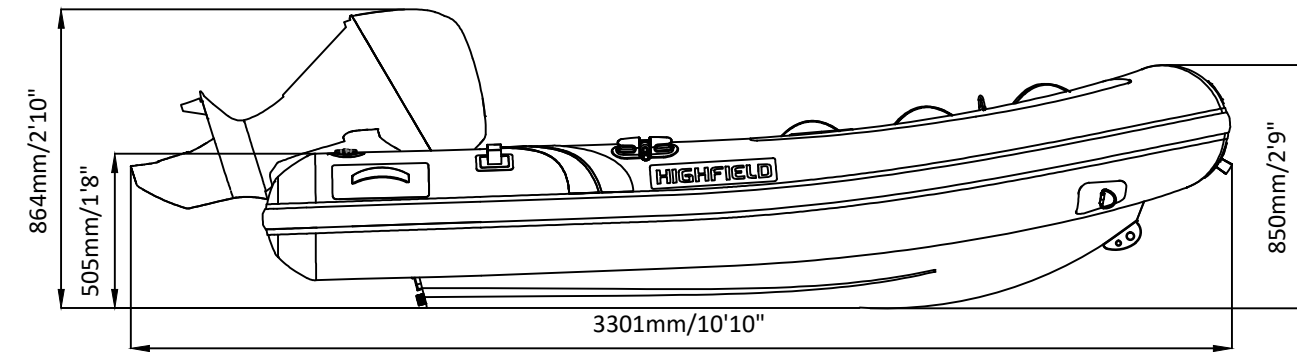

SPECIFICATIONS AND MAXIMUM CAPACITIES (Subject to change without notice. Tolerances: Dimensions ±2.5% Weight ±5%)

MODEL	ISO 6185 PART	ISO 6185			#			Shaft							/						AIR CHAMBERS						
			KG	LB		KG	LB		Max power	Max weight	KG	LB	KG	LB	KG	LB	L	GAL	Wet Weight (Approximate)	Wet Weight (Approximate)		PSI	BAR				
									KW	HP	KG	LB															
UL290FD	2	C	400	882	4	300	661	S	11.19	15	60	132	45	99	3	6.6	1.5	3.3	/	/	/	/	88	194	3	3.63	0.25

Weight: boat only.

2022V1